

# Challenger



## features & benefits

A double sided display with the convenience of a retractable banner stand. Constructed from aluminum and steel with two built in retractor mechanisms that allow you to present two graphics back-to-back and wide stabilizing feet. Bag included.

Challenger

Silver: CH-BF-30-S

Black: CH-BF-30-B

Challenger Mega

Silver: CH-BF-36-S

Black: CH-BF-36-B

# LetterBank

### hardware specifications

Height: 81.5

### graphic specifications

Challenger  
Graphic size: 29.5"W x 80"H  
(+ 6" bleed).  
Challenger Mega  
Graphic size: 35.5"W x 80"H  
(+6" bleed).  
Graphic type: Flexible inkjet, fabric or vinyl.  
0.012 (12 mil) max thickness

### additional info

Shipping weight:  
Challenger: 13 lbs.  
Challenger Mega 15 lbs.

Shipping dim:  
Challenger: 35"x9"x5"  
Challenger Mega 41"x9"x5"

Bag: black with red handle straps

# Assembly Instructions

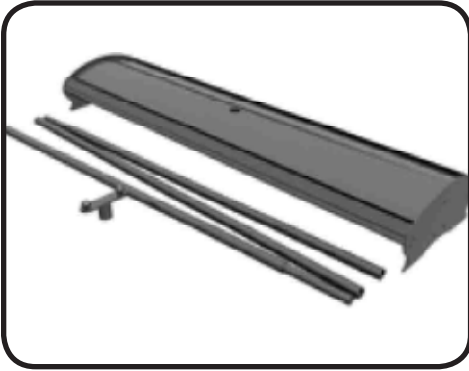

Remove the system from outer packaging and carry bag. Make sure to remove the adapter from the bag.

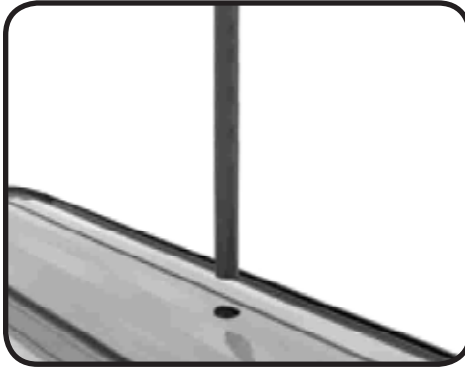

Connect the poles. Insert one end of the pole into the hole on the top of the system.



Place the adapter on the top of the pole.

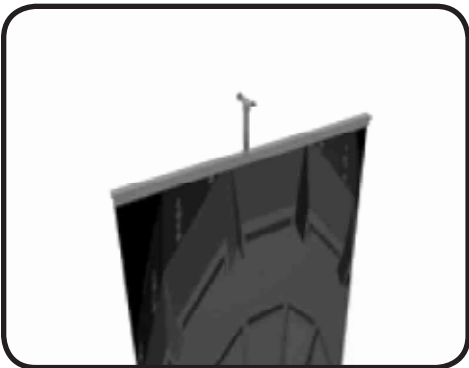

Grip one graphic rail and carefully pull it up.

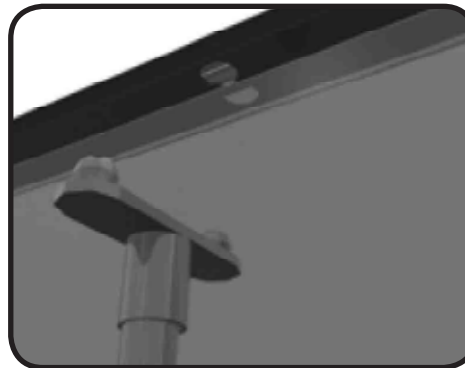

Pull the graphic about 2 inches above the adapter. Lower the graphic rail onto the ball of the adapter.



Repeat the process for the second graphic rail.

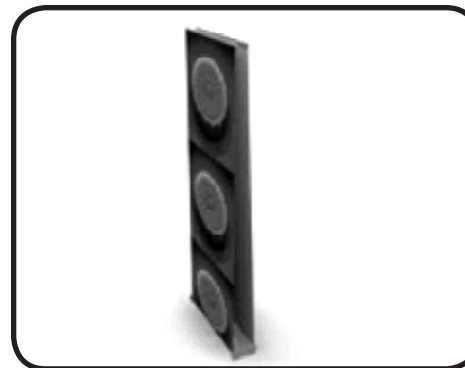

Your system is now ready to be used.

Reverse the procedure to disassemble. Take care when lowering the graphic, make sure it stays central to the system or you may damage your graphic.

Feet can be set-up 3 different ways

