

User Instructions

Challenger Plus Big Foot

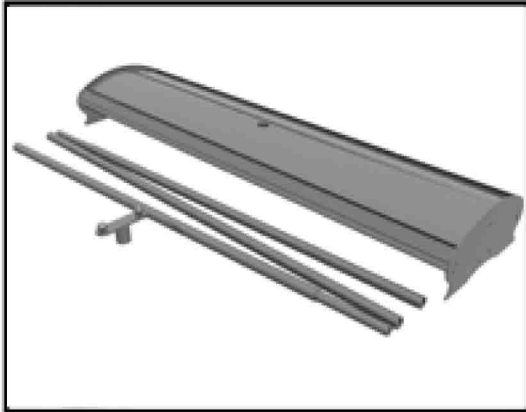

Remove the system from outer packaging and carry bag. Make sure to remove the adapter from the bag.

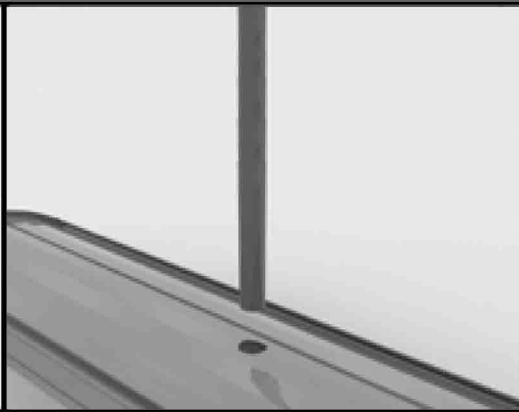

Connect the poles. Insert one end of the pole into the hole on the top of the system



Place the adapter of top of the pole.

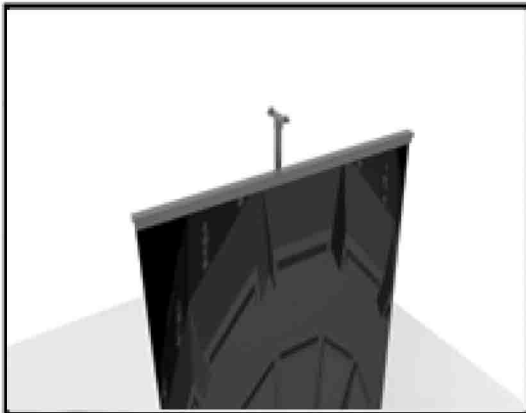

Grip one graphic rail and carefully pull it up.

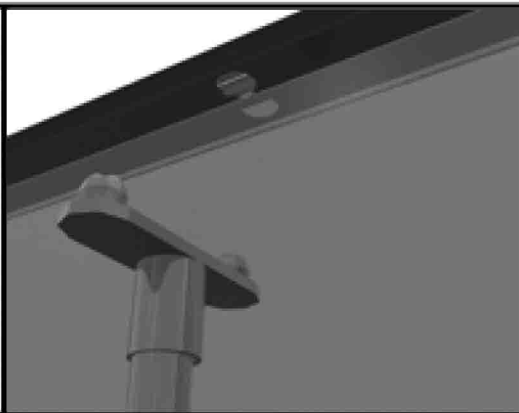

Pull the graphic about 2 inches above the adapter. Lower the graphic rail onto the ball of the adapter.



Repeat the process for the second graphic rail.

Product Details
 Color: silver or black
 Bag: black with red handle straps
 Weight of Base: 8 lbs
 Profile of Base: 7"D x 36"W x 3"T
 Height of Display: 81.5"
 Graphic Size: 35.5 x 80 (+6" bleed)
 Graphic Type: flexible inkjet, fabric or vinyl 0.012"(12 mil) max thickness
 Shipping Size: 41" x 9" x 5"
 Shipping Weight: 14 lbs

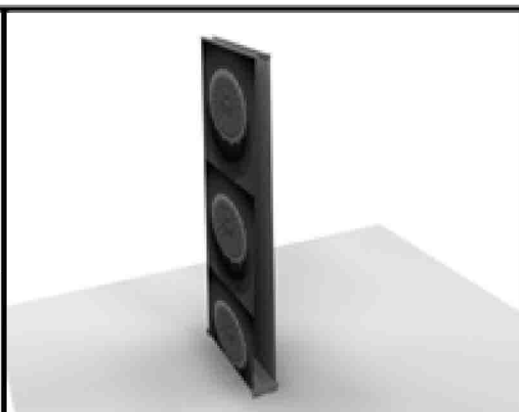

Reverse the procedure to disassemble. Take care when lowering the graphic. Make sure it stays central to the system or you may damage your graphic.

Feet can be set-up in 3 different ways



Your system is now ready to be used.